

lenovo

ThinkCentre
Safety and Warranty Guide



ThinkThink**ThinkCentre**Think

Inside

- Important safety information**
- Setting up your computer**
- Information resources**
- Warranty and other notices**
- Customer Replaceable Units (CRUs)**

Note:

Before using this information and the product it supports, be sure to read and understand the following:

- Chapter 1 “Important safety information” on page 1
- Chapter 4 “Warranty” on page 19
- Chapter 7 “Notices” on page 39

First Edition (December 2011)

© Copyright Lenovo 2011.

LIMITED AND RESTRICTED RIGHTS NOTICE: If data or software is delivered pursuant a General Services Administration “GSA” contract, use, reproduction, or disclosure is subject to restrictions set forth in Contract No. GS-35F-05925.

Contents

Chapter 1. Important safety information	1
Conditions that require immediate action	1
General safety guidelines	2
Batteries	2
Electrical current safety information	3
Lithium coin cell battery notice	4
Modem safety information	4
Laser compliance statement	5
Products with television tuner options installed	5
Note to CATV system installer	5
Example of antenna grounding	6
Data safety	7
Using headphones or earphones	7
Additional safety information	8
Chapter 2. Setting up your computer	9
Connecting your computer	9
Turning on computer power	13
Completing the software installation	14
Completing important tasks	14
Shutting down the computer	14
Chapter 3. Information resources	15
User Guide	15
Lenovo ThinkVantage Tools	15
ThinkVantage Productivity Center	16
Lenovo Welcome	16
Lenovo Web site (http://www.lenovo.com)	16
Lenovo Support Web site	17
Recording your computer information	17
Chapter 4. Warranty	19
Warranty Service Information	19
Suplemento de Garantía para México	29
Chapter 5. Worldwide Lenovo Support telephone list	31
Chapter 6. Customer Replaceable Units (CRUs)	37

Chapter 7. Notices	39
Trademarks	40
Electronic emission notices	40
Federal Communications Commission (FCC) and telephone company requirements	40
Canadian Department of Communications certification label	41
Polyvinyl Chloride (PVC) cable and cord notice	42
China substance disclosure table	43
China recycling information for Waste Electrical and Electronic Equipment (WEEE)	43
Turkish statement of compliance	43
Ukraine RoHS Statement	44
ENERGY STAR model information	44

Chapter 1. Important safety information

Note: Be sure to read and understand the important safety information first.

This information can help you safely use your desktop or notebook personal computer. Follow and retain all information included with your computer. The information in this document does not alter the terms of your purchase agreement or the Lenovo® Limited Warranty. For more information, refer to Chapter 4 “Warranty” on page 19.

Customer safety is important. Our products are developed to be safe and effective. However, personal computers are electronic devices. Power cords, power adapters, and other features can create potential safety risks that can result in physical injury or property damage, especially if misused. To reduce these risks, follow the instructions included with your product, observe all warnings on the product and in the operating instructions, and review the information included in this document carefully. By carefully following the information contained in this document and provided with your product, you can help protect yourself from hazards and create a safer computer work environment.

Note: This information includes references to power adapters and batteries. In addition to notebook computers, some products (such as speakers and monitors) are shipped with external power adapters. If you have such a product, this information applies to your product. In addition, computer products contain a coin-sized internal battery that provides power to the system clock even when the computer is unplugged, so the battery safety information applies to all computer products.

Conditions that require immediate action

Products can become damaged due to misuse or neglect. Some product damage is serious enough that the product should not be used again until it has been inspected and, if necessary, repaired by an Authorized Service Provider.

As with any electronic device, pay close attention to the product when it is turned on. On very rare occasions, you might notice an odor or see a puff of smoke or sparks vent from your product. Or you might hear sounds like popping, cracking, or hissing. These conditions might merely mean that an internal electronic component has failed in a safe and controlled manner. Or, they might indicate a potential safety issue. However, do not take risks or attempt to diagnose the situation yourself. Contact the Customer Support Center for further guidance. For a list of Service and Support phone numbers, see Chapter 5 “Worldwide Lenovo Support telephone list” on page 31.

Frequently inspect your computer and its components for damage, wear, or signs of danger. If you have any question about the condition of a

component, do not use the product. Contact the Customer Support Center or the product manufacturer for instructions on how to inspect the product and have it repaired, if necessary.

In the unlikely event that you notice any of the following conditions, or if you have any safety concerns with your product, stop using the product and unplug it from the power source and telecommunication lines until you can speak to the Customer Support Center for further guidance.

- Power cords, plugs, power adapters, extension cords, surge protectors, or power supplies that are cracked, broken, or damaged.
- Signs of overheating, smoke, sparks, or fire.
- Damage to a battery (such as cracks, dents, or creases), discharge from a battery, or a buildup of foreign substances on the battery.
- A cracking, hissing, or popping sound, or strong odor that comes from the product.
- Signs that liquid has been spilled or an object has fallen onto the computer product, the power cord, or power adapter.
- The computer product, power cord, or power adapter has been exposed to water.
- The product has been dropped or damaged in any way.
- The product does not operate normally when you follow the operating instructions.

Note: If you notice these conditions with a product (such as an extension cord) that is not manufactured for or by Lenovo, stop using that product until you can contact the product manufacturer for further instructions, or until you get a suitable replacement.

General safety guidelines

Always observe the following precautions to reduce the risk of injury and property damage.

Batteries

All personal computers manufactured by Lenovo contain a non-rechargeable coin cell battery to provide power to the system clock. In addition, many mobile products, such as notebook computers, utilize a rechargeable battery pack to provide system power when in portable mode. Batteries supplied by Lenovo for use with your product have been tested for compatibility and should only be replaced with approved parts.

Never attempt to open or service any battery. Do not crush, puncture, or incinerate batteries or short circuit the metal contacts. Do not expose the battery to water

or other liquids. Only recharge the battery pack strictly according to instructions included in the product documentation.

Battery abuse or mishandling can cause the battery to overheat, which can cause gasses or flame to “vent” from the battery pack or coin cell. If your battery is damaged, or if you notice any discharge from your battery or the buildup of foreign materials on the battery leads, stop using the battery and obtain a replacement from the battery manufacturer.

Batteries can degrade when they are left unused for long periods of time. For some rechargeable batteries (particularly Lithium Ion batteries), leaving a battery unused in a discharged state could increase the risk of a battery short circuit, which could shorten the life of the battery and can also pose a safety hazard. Do not let rechargeable Lithium-ion batteries completely discharge or store these batteries in a discharged state.

Electrical current safety information



Electrical current from power, telephone, and communication cables is hazardous.

To avoid a shock hazard:

- **To prevent possible shock hazard, do not use your computer during a lightning storm.**
- **Do not connect or disconnect any cables or perform installation, maintenance, or reconfiguration of this product during an electrical storm.**
- **Connect all power cords to a properly wired and grounded electrical outlet.**
- **Connect to properly wired outlets any equipment that will be attached to this product.**
- **When possible, use one hand only to connect or disconnect signal cables.**
- **Never turn on any equipment when there is evidence of fire, water, or structural damage.**
- **Disconnect the attached power cords, telecommunications systems, networks, and modems before you open the device covers, unless instructed otherwise in the installation and configuration procedures.**
- **Connect and disconnect cables as described in the following table when installing, moving, or opening covers on this product or attached devices.**

To connect:	To disconnect:
<ol style="list-style-type: none">1. Turn everything OFF.2. First, attach all cables to devices.3. Attach signal cables to connectors.4. Attach power cords to outlet.5. Turn device ON.	<ol style="list-style-type: none">1. Turn everything OFF.2. First, remove power cords from outlet.3. Remove signal cables from connectors.4. Remove all cables from devices.

Lithium coin cell battery notice



DANGER

Danger of explosion if battery is incorrectly replaced.

When replacing the lithium coin cell battery, use only the same or an equivalent type that is recommended by the manufacturer. The battery contains lithium and can explode if not properly used, handled, or disposed of.

Do not:

- **Throw or immerse into water**
- **Heat to more than 100°C (212°F)**
- **Repair or disassemble**

Dispose of the battery as required by local ordinances or regulations.

The following statement applies to users in the state of California, U.S.A.

California Perchlorate Information:

Products containing CR (manganese dioxide) lithium coin cell batteries may contain perchlorate.

Perchlorate Material - special handling may apply, See www.dtsc.ca.gov/hazardouswaste/perchlorate

Modem safety information

CAUTION:

To reduce the risk of fire, use only No. 26 AWG or larger (for example, No. 24 AWG) telecommunication line cord listed by Underwriters Laboratories (UL) or certified by the Canadian Standards Association (CSA).

Laser compliance statement



CAUTION:

When laser products (such as CD-ROMs, DVD drives, fiber optic devices, or transmitters) are installed, note the following:

- **Do not remove the covers.** Removing the covers of the laser product could result in exposure to hazardous laser radiation. There are no serviceable parts inside the device.
- **Use of controls or adjustments or performance of procedures other than those specified herein might result in hazardous radiation exposure.**



DANGER

Some laser products contain an embedded Class 3A or Class 3B laser diode. Note the following.

Laser radiation when open. Do not stare into the beam, do not view directly with optical instruments, and avoid direct exposure to the beam.

Products with television tuner options installed

The notice below applies to products containing television (TV) tuner devices that connect to external antennas or to cable/CATV systems, or both, and that are intended to be installed in North America. Users and installers in other countries should follow local codes and ordinances when installing appliances that connect to external antennas and cable/CATV systems. If local codes are not applicable, it is recommended that users/installers follow guidelines similar to those that follow.

Note to CATV system installer

This reminder is provided to call the CATV system installer's attention to Article 820-40 of the National Electrical Code (NEC) that provides guidelines for proper grounding and, in particular, specifies that the cable ground shall be connected to the grounding system of the building, as close as possible to the point of cable entry as practical.

Example of antenna grounding

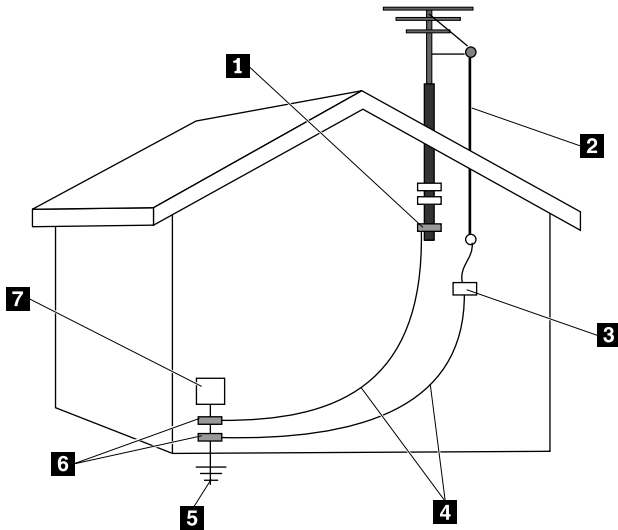

- | | | | |
|----------|---|----------|--|
| 1 | Ground clamp | 5 | Power service grounding electrode system (NEC Article 250, Part H) |
| 2 | Antenna lead-in wire | 6 | Ground clamps |
| 3 | Antenna discharge unit (NEC Section 810-20) | 7 | Electronic service equipment |
| 4 | Grounding conductors (NEC Section 810-21) | | |

Figure 1. Proper grounding for the cable

The following notice applies to all countries and regions:



DANGER

Outdoor antenna grounding

If an outside antenna or cable system is connected to the equipment, be sure the antenna or cable system is grounded as to provide some protection against voltage surges and built-up static charges.

Lightning

For added protection for this equipment during a lightning storm, or when it is left unattended and unused for long periods of time, unplug it from the wall outlet and disconnect the antenna or cable system. This will prevent damage to the video product due to lightning and power line surges.

Power lines

An outside antenna system should not be located in the vicinity of overhead power lines or where it can fall into such power lines or circuits. When installing an outside antenna system, extreme care should be taken to keep from touching such power lines or circuits, as contact with them may be fatal.

Data safety

Do not delete unknown files or change the name of files or directories that were not created by you; otherwise, your computer software might fail to work.

Be aware that accessing network resources can leave your computer vulnerable to computer viruses, hackers, spyware, and other malicious activities that might damage your computer, software, or data. It is your responsibility to ensure that you have adequate protection in the form of firewalls, antivirus software, and anti-spyware software and keep this software up to date.

Using headphones or earphones

If your computer has both a headphone connector and an audio line-out connector, always use the headphone connector for headphones (also called a headset) or earphones.

CAUTION:

Excessive sound pressure from earphones and headphones can cause hearing loss. Adjustment of the equalizer to maximum increases the earphone and headphone output voltage and the sound pressure level. Therefore, to protect your hearing, adjust the equalizer to an appropriate level.

Excessive use of headphones or earphones for a long period of time at high volume can be dangerous if the output of the headphone or earphone connectors do not comply with specifications of EN 50332-2. The headphone output connector of your computer complies with EN 50332-2 Sub clause 7. This

specification limits the computer's maximum wide band true RMS output voltage to 150 mV. To help protect against hearing loss, ensure that the headphones or earphones you use also comply with EN 50332-2 (Clause 7 Limits) for a wide band characteristic voltage of 75 mV. Using headphones that do not comply with EN 50332-2 can be dangerous due to excessive sound pressure levels.

If your Lenovo computer came with headphones or earphones in the package, as a set, the combination of the headphones or earphones and the computer already complies with the specifications of EN 50332-1. If different headphones or earphones are used, ensure that they comply with EN 50332-1 (Clause 6.5 Limitation Values). Using headphones that do not comply with EN 50332-1 can be dangerous due to excessive sound pressure levels.

Additional safety information

CAUTION:

Plastic bags can be dangerous. Keep plastic bags away from babies and children to avoid danger of suffocation.

Chapter 2. Setting up your computer

Before you begin, make sure you set up your computer in the best possible work area that suits your needs and the kind of work you do. For more information, see the *ThinkCentre User Guide* or go to: <http://www.lenovo.com/healthycomputing>

Note: Be sure to read and understand Chapter 1 “Important safety information” on page 1 before you set up your computer. The precautions and guidelines will help you work safely.

Connecting your computer

Use the following information when connecting your computer.

- Look for the small connector icons on the back of your computer. Match the connectors to the icons.
- If your computer cables and connector panel have color-coded connectors, match the color of the cable end with the color of the connector. For example, match a blue cable end with a blue connector or a red cable end with a red connector.

Note: Depending on your model type, your computer might not have all the connectors that are described in this section.

1. Connect the keyboard cable to the appropriate keyboard connector, either the Personal System/2 (PS/2) keyboard connector **1** or the Universal Serial Bus (USB) connector **2**.

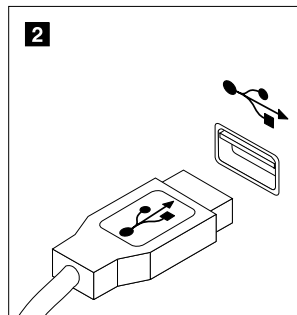
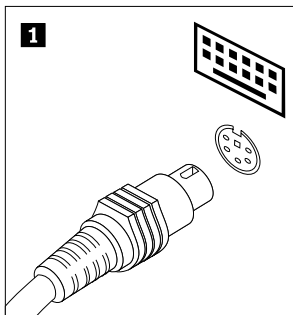

Note: Some models will have a keyboard with a fingerprint reader.

2. Connect the mouse cable to the appropriate mouse connector, either the PS/2 mouse connector **1** or the USB connector **2**.

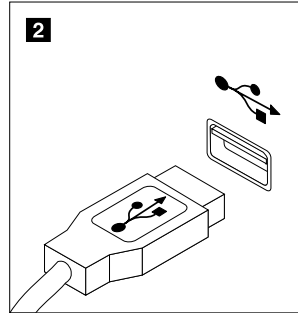
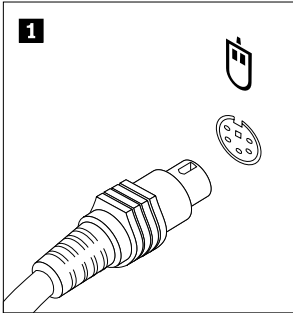

3. Connect the monitor cable to the monitor connector on the computer.
- If you have a Video Graphics Array (VGA) standard monitor, connect the cable to the connector as shown.

Note: If your computer has two monitor connectors, be sure to use the monitor connector on the graphics card.

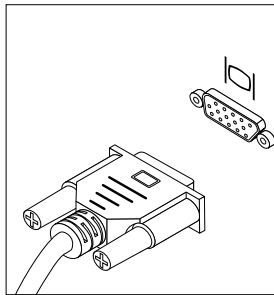

- If you have a high-performance monitor or a direct-drive monitor that uses a DisplayPort connector, connect the cable to the connector as shown.

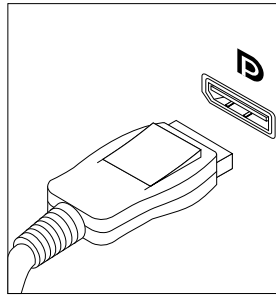

4. If you have a modem, connect the modem using the following information.

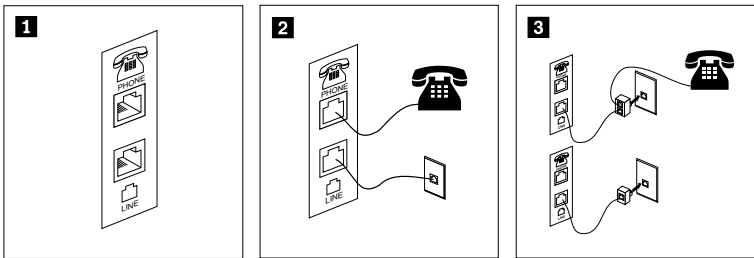

- 1** This illustration shows the two connectors on the back of the computer that are needed to set up your modem.
- 2** In the United States and other countries or regions that use the RJ-11 telephone outlet, attach one end of the telephone cable to the telephone and the other end to the telephone connector on the back of the computer. Attach one end of the modem cable to the modem connector on the back of the computer and the other end to the telephone outlet.
- 3** In countries or regions that do not use RJ-11 telephone outlets, a splitter or converter is required to attach the cables to the telephone outlet, as shown at the top of the illustration. You also can use the splitter or converter without the telephone, as shown at the bottom of the illustration.

5. If you have audio devices, attach them using the following instructions. For more information about speakers, see steps 6 and 7.

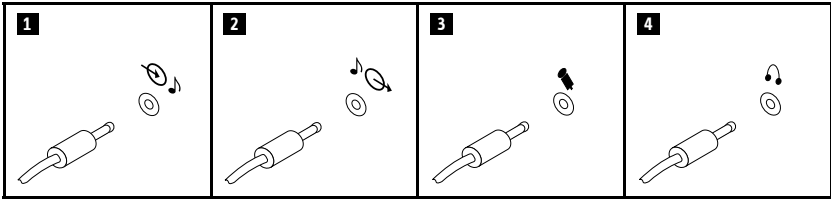

- 1** Audio line-in connector This connector receives audio signals from an external audio device, such as a stereo system.
- 2** Audio line-out connector This connector sends audio signals from the computer to external devices, such as powered stereo speakers.
- 3** Microphone connector Use this connector to attach a microphone to your computer when you want to record sound or if you use speech-recognition software.
- 4** Headphone connector Use this connector to attach headphones to your computer when you want to listen to music or other sounds without disturbing anyone.

6. If you have powered speakers with an ac power adapter:
 - a. Connect the cable that runs between the speakers, if necessary. On some speakers, this cable is permanently attached.
 - b. Connect the ac power adapter cable to the speakers.
 - c. Connect the speakers to the audio line-out connector or the headphone connector on the computer. See step 5.
 - d. Connect the ac power adapter to the ac power source.
7. If you have unpowered speakers with no ac power adapter:
 - a. Connect the cable that runs between the speakers, if necessary. On some speakers, this cable is permanently attached.
 - b. Connect the speakers to the audio line-out connector or the headphone connector on the computer. See step 5.
8. Connect any additional devices that you have. Your computer might not have all connectors that are shown.

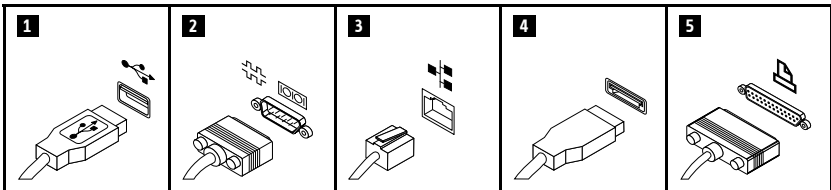

- 1** USB connector Use this connector to attach a device that requires a USB connection, such as a keyboard, a mouse, a scanner, a printer, or a personal digital assistant (PDA).
 - 2** Serial port Use this port to attach an external modem, a serial printer, or other devices that use a 9-pin serial port.
 - 3** Ethernet connector Use this connector to attach the computer to an Ethernet-type local area network or to a cable modem.
- Important:** To operate the computer within FCC limits when it is connected to an Ethernet network, use a Category 5 Ethernet cable.
- 4** eSATA connector Use this external Serial Advanced Technology Attachment (eSATA) connector to attach an external hard disk drive.
 - 5** Parallel port Use this port to attach a parallel printer or other devices that use a 25-pin parallel port.

9. Connect the power cords or the power adapter to properly grounded electrical outlets.

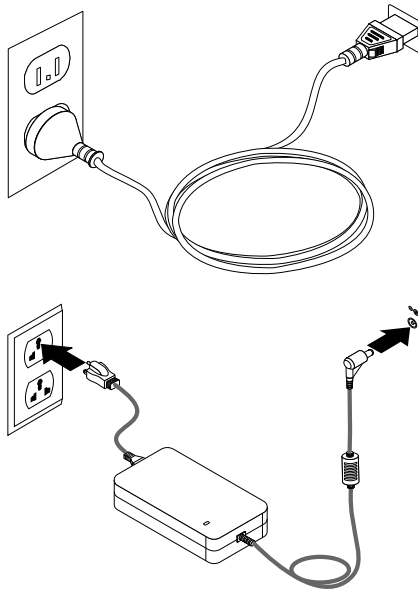

Turning on computer power

Turn on the monitor and other external devices first, and then turn on the computer. When the power-on self-test (POST) is finished, the logo window closes. If your computer has preinstalled software, the software installation program starts.

Completing the software installation

Important: Read the license agreements carefully before using the programs on this computer. These agreements detail your rights, obligations, and warranties for the software on this computer. By using these programs, you accept the terms of the agreements. If you do not accept the agreements, do not use the programs. Instead, promptly return the entire computer for a full refund.

The first time you start your computer, follow the instructions on the screen to complete the software installation. If you do not complete the software installation the first time you start your computer, unpredictable results might occur.

Note: Some models might have a multilingual version of Microsoft® Windows® operating system preinstalled. If your computer has the multilingual version, you will be prompted to choose a language during the installation process. After installation, the language version can be changed through the Windows Control Panel.

Completing important tasks

After you have set up your computer, record your computer machine type, model, and serial number. If you need service or technical support, you will probably be asked for this information.

Shutting down the computer

When you turn off your computer, always follow the shutdown procedure for your operating system. This prevents the loss of unsaved data or damage to your software programs.

- To shut down the Microsoft Windows 7 operating system, open the **Start** menu from the Windows desktop and click **Shut down**.
- To shut down the Microsoft Windows Vista® operating system, open the **Start** menu from the Windows desktop, move the cursor to the arrow next to the lock workstation button, and select **Shut Down**.

Chapter 3. Information resources

After you have set up your computer, you can use the information in this chapter to access useful resources relating to your computing needs.

User Guide

The *ThinkCentre User Guide* provides information about your computer to help you set up, use, and maintain your computer. It requires no Internet access to view the publication.

- To view the User Guide on the Windows 7 operating system, click **Start → Help and Support → Lenovo User Guide**.
- To view the User Guide on the Windows Vista operating system, click **Start → All Programs → ThinkVantage → Lenovo User Guide**.

The publication is also available on the Lenovo Support Web site at:
<http://www.lenovo.com/ThinkCentreUserGuides>

Notes:

1. The publication is in Portable Document Format (PDF). To view the publication, you need to have the Adobe Reader program preinstalled on your computer. If the Adobe Reader program has not been installed on your computer, a message will appear when you attempt to view the PDF file and you will be guided through the Adobe Reader program installation.
2. The publication is available in other languages on the Lenovo Support Web site at:
<http://www.lenovo.com/ThinkCentreUserGuides>
3. If you want to install a different language version of the Adobe Reader program rather than the version preinstalled on your computer, download the desired language version from the Adobe Web site at:
<http://www.adobe.com>

Lenovo ThinkVantage Tools

The Lenovo ThinkVantage® Tools program guides you to a host of information sources and provides easy access to various tools to help you work more easily and securely.

Note: The Lenovo ThinkVantage Tools program is only available on computers preinstalled with the Windows 7 operating system from Lenovo.

To access the Lenovo ThinkVantage Tools program, click **Start → All Programs → Lenovo ThinkVantage Tools**.

ThinkVantage Productivity Center

The ThinkVantage Productivity Center program guides you to a host of information sources and provides easy access to various tools to help you work more easily and securely.

The ThinkVantage Productivity Center program provides easy access to various technologies, such as:

- Client Security Solution
- Power Manager
- Product Recovery
- Rescue and Recovery®
- System Update

Note: The ThinkVantage Productivity Center program is only available on computers preinstalled with the Windows Vista operating system from Lenovo.

To access the ThinkVantage Productivity Center program, click **Start → All Programs → ThinkVantage → Productivity Center**.

Lenovo Welcome

The Lenovo Welcome program introduces you to some innovative built-in features of Lenovo and guides you through a few important setup tasks to help you make the most of your computer.

Lenovo Web site (<http://www.lenovo.com>)

The Lenovo Web site provides up-to-date information and services to help you buy, upgrade, and maintain your computer. You can also do the following:

- Shop for desktop and notebook computers, monitors, projectors, upgrades and accessories for your computer, and special offers.
- Purchase additional services, such as support for hardware, operating systems, application programs, network setup and configuration, and custom installations.
- Purchase upgrades and extended hardware repair services.
- Download the latest device drivers and software updates for your computer model.
- Access the online manuals for your products.
- Access the Lenovo Limited Warranty.
- Access troubleshooting and support information for your computer model and other supported products.

- Find the service and support phone numbers for your country or region.
- Find a Service Provider located near you.

Lenovo Support Web site

Technical support information is available on the Lenovo Support Web site at: <http://www.lenovo.com/support>

This Web site is updated with the latest support information such as the following:

- Drivers and software
- Diagnostic solutions
- Product and service warranty
- Product and parts details
- User guides and manuals
- Knowledge base and frequently asked questions

Recording your computer information

Recording information about your computer can be helpful if you ever need to have your computer serviced. The service technician will probably ask you for this information.

The machine type, model, and serial number are labeled on your computer. Use the following table to record this information.

Product name	_____
Machine type and model	_____
Serial number (S/N)	_____
Date of purchase	_____

You can register your computer by following the instructions at: <http://www.lenovo.com/register>

You will receive the following benefits after registering your computer:

- Faster service when you call for help

- Automatic notification of free software and special promotional offers

Chapter 4. Warranty

The Lenovo Limited Warranty is available at:
http://www.lenovo.com/warranty/llw_02

Warranty Service Information

Machine Type	Country or Region of Purchase	Warranty Period	Type of Warranty Service
0267*	United States, Canada, Latin America (except Brazil), Europe, Middle East, Africa	Parts and labor - 4 years	1 and 2
	Brazil, Australia, New Zealand, Singapore, Malaysia, Thailand, Indonesia, Philippines, Vietnam, Brunei, Sri Lanka, Bangladesh, Japan, Korea, China, Hong Kong S.A.R. of China, Taiwan	Parts and labor - 4 years	1 and 2
		Keyboard and mouse - 1 year	1
	India	Parts and labor - 4 years	1 and 2
		Keyboard and mouse - 4 years	4
	0268*	United States, Canada, Latin America (except Brazil), Europe, Middle East, Africa	Parts and labor - 4 years
Brazil, Australia, New Zealand, Singapore, Malaysia, Thailand, Indonesia, Philippines, Vietnam, Brunei, Sri Lanka, Bangladesh, Japan, Korea, China, Hong Kong S.A.R. of China, Taiwan		Parts and labor - 4 years	1 and 2
		Keyboard and mouse - 1 year	1
India		Parts and labor - 4 years	1 and 2
		Keyboard and mouse - 4 years	4

Machine Type	Country or Region of Purchase	Warranty Period	Type of Warranty Service
0385*	United States, Canada, Latin America (except Brazil), Europe, Middle East, Africa	Parts and labor - 3 years	1 and 2
	Brazil, Australia, New Zealand, Singapore, Malaysia, Thailand, Indonesia, Philippines, Vietnam, Brunei, Sri Lanka, Bangladesh, Japan, Korea, China, Hong Kong S.A.R. of China, Taiwan	Parts and labor - 3 years	1 and 2
		Keyboard and mouse - 1 year	1
	India	Parts and labor - 3 years	1 and 2
		Keyboard and mouse - 3 years	4
1730*	United States, Canada, Latin America (except Brazil), Europe, Middle East, Africa	Parts and labor - 3 years	1 and 2
	Brazil, Australia, New Zealand, Singapore, Malaysia, Thailand, Indonesia, Philippines, Vietnam, Brunei, Sri Lanka, Bangladesh, Japan, Korea, China, Hong Kong S.A.R. of China, Taiwan	Parts and labor - 3 years	1 and 2
		Keyboard and mouse - 1 year	1
	India	Parts and labor - 3 years	1 and 2
		Keyboard and mouse - 3 years	4

Machine Type	Country or Region of Purchase	Warranty Period	Type of Warranty Service
4164	United States, Canada, Latin America (except Brazil), Europe, Middle East, Africa	Parts and labor - 4 years	1 and 2
	Brazil, Australia, New Zealand, Singapore, Malaysia, Thailand, Indonesia, Philippines, Vietnam, Brunei, Sri Lanka, Bangladesh, Japan, Korea, China, Hong Kong S.A.R. of China, Taiwan	Parts and labor - 4 years	1 and 2
		Keyboard and mouse - 1 year	1
	India	Parts and labor - 4 years	1 and 2
		Keyboard and mouse - 4 years	4
4166	United States, Canada, Latin America (except Brazil), Europe, Middle East, Africa	Parts and labor - 1 year	1 and 2
	Brazil, Australia, New Zealand, Singapore, Malaysia, Thailand, Indonesia, Philippines, Vietnam, Brunei, Sri Lanka, Bangladesh, Japan, Korea, Hong Kong S.A.R. of China, Taiwan	Parts and labor - 1 year	1 and 2
		Keyboard and mouse - 1 year	1
	India	Parts and labor - 1 year	1 and 2
		Keyboard and mouse - 1 year	4

Machine Type	Country or Region of Purchase	Warranty Period	Type of Warranty Service
4167	United States, Canada, Latin America (except Brazil), Europe, Middle East, Africa	Parts and labor - 1 year	1 and 2
	Brazil, Australia, New Zealand, Singapore, Malaysia, Thailand, Indonesia, Philippines, Vietnam, Brunei, Sri Lanka, Bangladesh, Japan, Korea, Hong Kong S.A.R. of China, Taiwan	Parts and labor - 1 year	1 and 2
		Keyboard and mouse - 1 year	1
	India	Parts and labor - 1 year	1 and 2
		Keyboard and mouse - 1 year	4
4169	Europe, Middle East, Africa	Parts and labor - 3 years	1 and 4
	Australia, New Zealand, Singapore, Malaysia, Thailand, Indonesia, Philippines, Vietnam, Brunei, Sri Lanka, Bangladesh, Hong Kong S.A.R. of China, Taiwan	Parts - 3 years labor - 1 year	1 and 2
		Keyboard and mouse - 1 year	1
	India	Parts - 3 years labor - 1 year	1 and 2
		Keyboard and mouse - 3 years	4
5025	Europe, Middle East, Africa	Parts and labor - 3 years	1 and 4
	Australia, New Zealand, Singapore, Malaysia, Thailand, Indonesia, Philippines, Vietnam, Brunei, Sri Lanka, Bangladesh, Hong Kong S.A.R. of China, Taiwan	Parts - 3 years labor - 1 year	1 and 2
		Keyboard and mouse - 1 year	1
	India	Parts - 3 years labor - 1 year	1 and 2

Machine Type	Country or Region of Purchase	Warranty Period	Type of Warranty Service
		Keyboard and mouse - 3 years	4
5030	United States, Canada, Latin America (except Brazil), Europe, Middle East, Africa	Parts and labor - 3 years	1 and 2
	Brazil, Australia, New Zealand, Singapore, Malaysia, Thailand, Indonesia, Philippines, Vietnam, Brunei, Sri Lanka, Bangladesh, Japan, Korea, Hong Kong S.A.R. of China, Taiwan	Parts and labor - 3 years	1 and 2
		Keyboard and mouse - 1 year	1
	India	Parts and labor - 3 years	1 and 2
		Keyboard and mouse - 3 years	4
5032	United States, Canada, Latin America (except Brazil), Europe, Middle East, Africa	Parts and labor - 3 years	1 and 2
	Brazil, Australia, New Zealand, Singapore, Malaysia, Thailand, Indonesia, Philippines, Vietnam, Brunei, Sri Lanka, Bangladesh, Japan, Korea, Hong Kong S.A.R. of China, Taiwan	Parts and labor - 3 years	1 and 2
		Keyboard and mouse - 1 year	1
	India	Parts and labor - 3 years	1 and 2
		Keyboard and mouse - 3 years	4

Machine Type	Country or Region of Purchase	Warranty Period	Type of Warranty Service
5034	United States, Canada, Latin America (except Brazil), Europe, Middle East, Africa	Parts and labor - 3 years	1 and 2
	Brazil, Australia, New Zealand, Singapore, Malaysia, Thailand, Indonesia, Philippines, Vietnam, Brunei, Sri Lanka, Bangladesh, Japan, Korea, China, Hong Kong S.A.R. of China, Taiwan	Parts and labor - 3 years	1 and 2
		Keyboard and mouse - 1 year	1
	India	Parts and labor - 3 years	1 and 2
		Keyboard and mouse - 3 years	4
	5035	United States, Canada, Latin America (except Brazil), Europe, Middle East, Africa	Parts and labor - 3 years
Brazil, Australia, New Zealand, Singapore, Malaysia, Thailand, Indonesia, Philippines, Vietnam, Brunei, Sri Lanka, Bangladesh, Japan, Korea, China, Hong Kong S.A.R. of China, Taiwan		Parts and labor - 3 years	1 and 2
		Keyboard and mouse - 1 year	1
India		Parts and labor - 3 years	1 and 2
		Keyboard and mouse - 3 years	4

Machine Type	Country or Region of Purchase	Warranty Period	Type of Warranty Service
5037	United States, Canada, Latin America (except Brazil), Europe, Middle East, Africa	Parts and labor - 4 years	1 and 2
	Brazil, Australia, New Zealand, Singapore, Malaysia, Thailand, Indonesia, Philippines, Vietnam, Brunei, Sri Lanka, Bangladesh, Japan, Korea, China, Hong Kong S.A.R. of China, Taiwan	Parts and labor - 4 years	1 and 2
		Keyboard and mouse - 1 year	1
	India	Parts and labor - 4 years	1 and 2
		Keyboard and mouse - 4 years	4
5048*	United States, Canada, Latin America (except Brazil), Europe, Middle East, Africa	Parts and labor - 3 years	1 and 2
	Brazil, Australia, New Zealand, Singapore, Malaysia, Thailand, Indonesia, Philippines, Vietnam, Brunei, Sri Lanka, Bangladesh, Japan, Korea, Hong Kong S.A.R. of China, Taiwan	Parts and labor - 3 years	1 and 2
		Keyboard and mouse - 1 year	1
	India	Parts and labor - 3 years	1 and 2
		Keyboard and mouse - 3 years	4

Machine Type	Country or Region of Purchase	Warranty Period	Type of Warranty Service
5049*	United States, Canada, Latin America (except Brazil), Europe, Middle East, Africa	Parts and labor - 3 years	1 and 2
	Brazil, Australia, New Zealand, Singapore, Malaysia, Thailand, Indonesia, Philippines, Vietnam, Brunei, Sri Lanka, Bangladesh, Japan, Korea, Hong Kong S.A.R. of China, Taiwan	Parts and labor - 3 years	1 and 2
		Keyboard and mouse - 1 year	1
	India	Parts and labor - 3 years	1 and 2
		Keyboard and mouse - 3 years	4
5069	United States, Canada, Latin America (except Brazil), Europe, Middle East, Africa	Parts and labor - 1 year	1 and 2
	Brazil, Japan	Parts and labor - 1 year	1 and 2
		Keyboard and mouse - 1 year	1
5070	United States, Canada, Latin America (except Brazil), Europe, Middle East, Africa	Parts and labor - 1 year	1 and 2
	Brazil, Japan	Parts and labor - 1 year	1 and 2
		Keyboard and mouse - 1 year	1
7517	United States, Canada, Latin America (except Brazil), Europe, Middle East, Africa	Parts and labor - 3 years	1 and 2
	Brazil, Japan, Korea, Hong Kong S.A.R. of China, Taiwan	Parts and labor - 3 years	1 and 2
		Keyboard and mouse - 1 year	1

Machine Type	Country or Region of Purchase	Warranty Period	Type of Warranty Service
7518	United States, Canada, Latin America (except Brazil), Europe, Middle East, Africa	Parts and labor - 3 years	1 and 2
	Brazil, Japan, Korea, Hong Kong S.A.R. of China, Taiwan	Parts and labor - 3 years	1 and 2
		Keyboard and mouse - 1 year	1
Notes: 1. * denotes ENERGY STAR machines. For more information, see “ENERGY STAR model information” on page 44.			

If required, your Service Provider will provide repair or exchange service depending on the type of warranty service specified for your product and the available service. Scheduling of service will depend upon the time of your call, parts availability, and other factors.

Types of Warranty Service

1. Customer Replaceable Unit (“CRU”) Service

Under CRU Service, the Service Provider will ship CRUs to you at its cost for installation by you. CRU information and replacement instructions are shipped with your product and are available from Lenovo at any time upon request. CRUs that are easily installed by you are called “Self-service CRUs”. “Optional-service CRUs” are CRUs that may require some technical skill and tools. Installation of Self-service CRUs is your responsibility. You may request that a Service Provider install Optional-service CRUs under one of the other types of warranty service designated for your product. An optional service offering may be available for purchase from a Service Provider or Lenovo under which Self-service CRUs would be installed for you. You may find a list of CRUs and their designation in the publication that was shipped with your product or at www.lenovo.com/CRUs. The requirement to return a defective CRU, if any, will be specified in the instructions shipped with a replacement CRU. When return is required: 1) return instructions, a prepaid return shipping label, and a container will be included with the replacement CRU; and 2) you may be charged for the replacement CRU if the Service Provider does not receive the defective CRU from you within thirty (30) days of your receipt of the replacement CRU.

2. On-site Service

Under On-Site Service, a Service Provider will either repair or exchange the product at your location. You must provide a suitable working area to allow disassembly and reassembly of the product. Some repairs may need to be

completed at a service center. If so, the Service Provider will send the product to the service center at its expense.

3. Courier or Depot Service

Under Courier or Depot Service, your product will be repaired or exchanged at a designated service center, with shipping at the expense of the Service Provider. You are responsible for disconnecting the product and packing it in a shipping container provided to you to return your product to a designated service center. A courier will pick up your product and deliver it to the designated service center. The service center will return the product to you at its expense.

4. Customer Carry-In Service

Under Customer Carry-In Service, your product will be repaired or exchanged after you deliver it to a designated service center at your risk and expense. After the product has been repaired or exchanged, it will be made available to you for collection. If you fail to collect the product, the Service Provider may dispose of the product as it sees fit, with no liability to you.

5. Mail-In Service

Under Mail-In Service, your product will be repaired or exchanged at a designated service center after you deliver it at your risk and expense. After the product has been repaired or exchanged, it will be returned to you at Lenovo's risk and expense, unless the Service Provider specifies otherwise.

6. Customer Two-Way Mail-In Service

Under Customer Two-Way Mail-In Service, your product will be repaired or exchanged after you deliver it to a designated service center at your risk and expense. After the product has been repaired or exchanged, it will be made available to you for return shipping at your risk and expense. If you fail to arrange return shipment, the Service Provider may dispose of the product as it sees fit, with no liability to you.

7. Product Exchange Service

Under Product Exchange Service, Lenovo will ship a replacement product to your location. You are responsible for its installation and verification of its operation. The replacement product becomes your property in exchange for the failed product, which becomes the property of Lenovo. You must pack the failed product in the shipping carton in which you received the replacement product and return it to Lenovo. Transportation charges, both ways, shall be at Lenovo's expense. If you fail to use the carton in which the replacement product was received, you may be responsible for any damage to the failed product occurring during shipment. You may be charged for the replacement product if Lenovo does not receive the failed product within thirty (30) days of your receipt of the replacement product.

Suplemento de Garantía para México

Este Suplemento se considera parte integrante de la Garantía Limitada de Lenovo y será efectivo única y exclusivamente para los productos distribuidos y comercializados dentro del Territorio de los Estados Unidos Mexicanos. En caso de conflicto, se aplicarán los términos de este Suplemento.

Todos los programas de software precargados en el equipo sólo tendrán una garantía de treinta (30) días por defectos de instalación desde la fecha de compra. Lenovo no es responsable de la información incluida en dichos programas de software y/o cualquier programa de software adicional instalado por Usted o instalado después de la compra del producto.

Los servicios no cubiertos por la garantía se cargarán al usuario final, previa obtención de una autorización.

En el caso de que se precise una reparación cubierta por la garantía, por favor, llame al Centro de soporte al cliente al 001-866-434-2080, donde le dirigirán al Centro de servicio autorizado más cercano. Si no existiese ningún Centro de servicio autorizado en su ciudad, población o en un radio de 70 kilómetros de su ciudad o población, la garantía incluirá cualquier gasto de entrega razonable relacionado con el transporte del producto a su Centro de servicio autorizado más cercano. Por favor, llame al Centro de servicio autorizado más cercano para obtener las aprobaciones necesarias o la información relacionada con el envío del producto y la dirección de envío.

Para obtener una lista de los Centros de servicio autorizados, por favor, visite:
<http://www.lenovo.com/mx/es/servicios>

Importado por:
Lenovo México S. de R.L. de C.V.
Av. Santa Fe 505, Piso 15
Col. Cruz Manca
Cuajimalpa, D.F., México
C.P. 05349
Tel. (55) 5000 8500

Chapter 5. Worldwide Lenovo Support telephone list

Telephone numbers are subject to change without notice. The most up-to-date telephone list for Lenovo Support is always available at:

<http://www.lenovo.com/support/phone>

Country or region	Telephone number
Africa	Africa: +44 (0)1475-555-055 South Africa: +27-11-3028888, 0800110756 and +27-11- 3027252 Central Africa: Contact the nearest Lenovo Business Partner
Algeria	+33 6 7348 1739 (French, English)
Argentina	0800-666-0011 (Spanish)
Australia	131-426 (English)
Austria	01-24592-5901 43-810-100654 (Warranty service and support) (German)
Bahrain	Kanoo IT: 00 973 1771 1722 Bahrain Business Machine LLC: 00 973 1758 4302
Belgium	02-210-9820 +32 (0)2 339 3611 (Warranty service and support) (Dutch) 02-210-9800 (French)
Bolivia	0800-10-0189 (Spanish)
Brazil	Calls made from within the Sao Paulo region: (11) 3889-8986 Calls made from outside the Sao Paulo region: 0800-701-4815 (Brazilian Portuguese)
Brunei	801-1041 (English, Bahasa Melayu)
Canada	1-800-565-3344 (English, French)
Caribbean (Bermuda, Jamaica, Tortola)	1-800 426 7378 (English)
Chile	800-361-213 or 188-800-442-488 (Toll free) (Spanish)

Country or region	Telephone number
China	Technical Support Line 800-990-8888 86-10-58851110 (Mandarin)
China (Hong Kong S.A.R.)	ThinkCentre® Commercial PC: 8205-0333 ThinkCentre Multimedia Home PC: 2516-3969 (Cantonese, English, Mandarin)
China (Macau S.A.R.)	ThinkCentre Commercial PC: 0800-336 ThinkCentre Multimedia Home PC: 0800-336 (Cantonese, English, Mandarin)
Colombia	1-800-912-3021 (Spanish)
Costa Rica	0-800-011-1029 (Spanish)
Croatia	0800-0426
Cyprus	+357-22-841100
Czech Republic	+420-2-7213-1316
Denmark	4520-8200 7010-5150 (Warranty service and support) (Danish)
Dominican Republic	1-866-434-2080 (Spanish)
Ecuador	1-800-426911 (Spanish)
Egypt	202-25948500
El Salvador	800-6264 (Spanish)
Estonia	+372 66 00 800 +372 6776793
Finland	09-459-6960 +358-800-1-4260 (Warranty service and support) (Finnish)
France	0238-557-450 Hardware: 0810-631-213 (Warranty service and support) Software: 0810-631-020 (Warranty service and support) (French)
Germany	07032-15-49201 01805-00 46 18 (Warranty service and support) (German)
Greece	+30-210-680-1700
Guatemala	1800-624-0051 (Spanish)

Country or region	Telephone number
Honduras	Tegucigalpa: 232-4222 San Pedro Sula: 552-2234 (Spanish)
Hungary	+36 1 3825716 +36 1 3825720 (English, Hungarian)
India	1800-425-2666 or +91-80-2535-9183
Indonesia	021 5238 823 001-803-606-282 (Local number only) +603 8315 6859 (DID) (English, Bahasa Indonesia)
Ireland	01-815-9202 01-881-1444 (Warranty service and support) (English)
Israel	Givat Shmuel Service Center: +972-3-531-3900
Italy	02-7031-6101 +39-800-820094 (Warranty service and support) (Italian)
Japan	Toll Free: 0120-20-5550/5555 For International: +81-46-266-4716 Note: The above numbers will be answered with a Japanese language voice prompt. For telephone support in English, please wait for the Japanese voice prompt to end, and an operator will answer. Please ask for "English support please," and your call will be transferred to an English speaking operator. PC Software 0120-558-695 Overseas calls: +81-44-200-8666 (Japanese)
Jordan	Jordan Business Systems: 00 962 6 5000999 (ext. 713/127) General Computer & Electronic (GCE): 00 962 6 551 3879
Korea	1588-6782 (Korean)
Kuwait	Easa Hussain Al Yousifi: 00 965 2244 5280 AM. KHORAFI: 00 965 2200 1100 1127 Khorafi Business Machines (KBM): 00 965 2259 4611 Diyar United Company: 00 965 4378 383 Redington Kuwait: 00 965 2433 3203, 25456250 / 25456251

Country or region	Telephone number
Latvia	+371 7070360
Lebanon	Quantech: 00 961 1999 500 Computer Business Machine (CBM): 00 961 1680 180 El Haceb S.A.L: 00 961 1771 300
Lithuania	+370 5 278 66 00
Libya	+33 6 7348 1739 (French, English)
Luxembourg	+32 (0)2 339 3611 +35 229 8977 5063 (French)
Malaysia	1800-88-1889 (Local number only) +603 8315 6855 (DID) (English, Bahasa Melayu)
Malta	+35621445566
Mexico	001-866-434-2080 (Spanish)
Middle East	+44 (0)1475-555-055
Netherlands	+31 (0)20 513 3939 (Dutch)
New Zealand	0800-733-222 (English)
Nicaragua	001-800-220-1830 (Spanish)
Norway	6681-1100 8152-1550 (Warranty service and support) (Norwegian)
Oman	Khimji Ramdas Computer Communication Systems: 00 968 2469 6255 Overseas Business Machines (OBM): 00 968 2460 1072, 2460 5018 Gulf Business Machines Services: (GBMS) 00 968 2455 9831
Pakistan	INFO TECH (pvt) Ltd.: 00 924 2111 427 427 International Office Products (pvt) Ltd.: 00 92 212 422 569, 00 92 213 241 2023 Selling Business Systems: 00 92 21 568 9823
Panama	206-6047 001-866-434-2080 (Lenovo Customer Support Center - Toll free) (Spanish)
Paraguay	009-800-52-10026 (Spanish)
Peru	0-800-50-866 (Spanish)

Country or region	Telephone number
Philippines	1800-1601-0033 (Local number only) +603 8315 6858 (DID) (English, Filipino)
Poland	+48 22 760-73-00 (Polski)
Portugal	+351 21 892 7046 (Portuguese)
Qatar	Al Mana Computer Services: 00 974 4489 966 (ext. 1992) Qatar Computer Services W.L.L: 00 974 4441 212 Gulf Business Machines: 00-974 462 1395
Romania	+4-021-224-4015
RUCIS (Russia and CIS)	For Russia: 8 800 100 7888 (Toll free number) For CIS Countries: 0040 31 620 5099 (Payable) (Russian and English)
Saudi Arabia	800 8200140 (English, Arabic)
Singapore	800 6011 343 (Local number only) +603 8315 6856 (DID) (English)
Slovakia	+421 2 4974 8888
Slovenia	+386-1-200-50-60 (Slovenian)
Spain	91-714-7983 0901-100-000 (Spanish)
Sri Lanka	+9411 2493547 +9411 2493548 (English)
Sweden	08-477-4420 077-117-1040 (Warranty service and support) (Swedish)
Switzerland	058-333-0900 0800-55-54-54 (Warranty service and support) (German, French, Italian)
Taiwan	0800-000-702 (Mandarin)
Thailand	1 800-060-066 (Local number only) 66 2273 4088 +603 8315 6857 (DID) (Thai, English)
Turkey	00800-4463-2041 (Turkish)

Country or region	Telephone number
Ukraine	0800 507 333 0040 21 40 10 870 (Payable) (Ukrainian, Russian, English)
United Arab Emirates	800 02000141 (English, Arabic)
United Kingdom	01475-555-055 08705-500-900 (Standard warranty support) (English)
United States	1-800-426-7378 (Select "Option #1") (English)
Uruguay	000-411-005-6649 (Spanish)
Venezuela	0-800-100-2011 (Spanish)
Vietnam	For Northern Area and Hanoi City: 844 3 946 2000 or 844 3 942 6457 For Southern Area and Ho Chi Minh City: 848 3 829 5160 or 844 3 942 6457 (Vietnamese, English)
Yemen	Al Khirbash and Agencies & Trading Co.: 00 967 1209 8278 Yemen Business Machines (YBM): 00 967 3 213 324 / 214 655, 967 3 213 909 / 213 324

Chapter 6. Customer Replaceable Units (CRUs)

Customer Replaceable Units (CRUs) are computer parts that can be upgraded or replaced by the customer. There are two types of CRUs: *Self-service* and *Optional-service*. Self-service CRUs are easy to install. They might be standalone, latched, or require a screwdriver to remove a maximum of two screws. However, Optional-service CRUs require some technical skills and in some cases might also require simple tools, such as a screwdriver. However, both Self-service and Optional-service CRUs are safe for the customer to remove.

Customers are responsible for replacing all Self-service CRUs. Optional-service CRUs can be removed and installed by customers or by a Lenovo service technician during the warranty period. Lenovo desktop computers contain both Self-service and Optional-service CRUs.

- Self-service CRUs: These CRUs unplug or are secured by no more than two screws. Examples of these types of CRUs include the keyboard, the mouse, any USB device, and the power cord. Other Self-service CRUs depending on product design might include memory modules, adapter cards, hard disk drives, and optical drives.
- Optional-service CRUs: These CRUs are isolated parts within the computer and are concealed by an access panel that is typically secured by more than two screws. Once the access panel is removed, the specific CRU is visible.
- Both types of CRUs are listed in the tables on the following page.

The *ThinkCentre User Guide* provides instructions for replacing Self-service and Optional-service CRUs. Refer to the following tables for the CRU information in your *ThinkCentre User Guide*. If your computer model has a Windows 7 operating system, you can view the publication by clicking **Start → Help and Support → Lenovo User Guide**. If your computer model has a Windows Vista operating system, you can view the publication by clicking **Start → All Programs → ThinkVantage → Lenovo User Guide**. Double-click the publication for your computer. You can also access the publication on the Lenovo Support Web site at: <http://www.lenovo.com/ThinkCentreUserGuides>

Note: Use only computer parts provided by Lenovo. Refer to Lenovo Limited Warranty on the warranty viewer or http://www.lenovo.com/warranty/llw_02.

You can find the replacement instructions for the following CRUs in the *ThinkCentre User Guide*.

The following table lists the CRU information for the following machine types: 0267, 0385, 4164, 4167, 5025, 5032, 5035, 5049, 5070, and 7518.

Self-service CRUs	Optional-service CRUs
Battery Hard disk drive Keyboard Memory module Mouse Optical drive Peripheral Component Interconnect (PCI) card	Card reader (optional) Front audio and USB assembly Heat sink and fan assembly Internal speaker (optional) Microprocessor Power supply assembly

The following table lists the CRU information for the following machine types: 0268, 1730, 4166, 4169, 5030, 5034, 5037, 5048, 5069, and 7517.

Self-service CRUs	Optional-service CRUs
Battery Front fan assembly (optional) Hard disk drive Keyboard Memory module Mouse Peripheral Component Interconnect (PCI) card Rear fan assembly	Card reader (optional) Front audio and USB assembly Heat sink and fan assembly Internal speaker (optional) Microprocessor Optical drive Power supply assembly

Chapter 7. Notices

Lenovo may not offer the products, services, or features discussed in this document in all countries. Consult your local Lenovo representative for information on the products and services currently available in your area. Any reference to a Lenovo product, program, or service is not intended to state or imply that only that Lenovo product, program, or service may be used. Any functionally equivalent product, program, or service that does not infringe any Lenovo intellectual property right may be used instead. However, it is the user's responsibility to evaluate and verify the operation of any other product, program, or service.

Lenovo may have patents or pending patent applications covering subject matter described in this document. The furnishing of this document does not give you any license to these patents. You can send license inquiries, in writing, to:

*Lenovo (United States), Inc.
1009 Think Place - Building One
Morrisville, NC 27560
U.S.A.
Attention: Lenovo Director of Licensing*

LENOVO PROVIDES THIS PUBLICATION "AS IS" WITHOUT WARRANTY OF ANY KIND, EITHER EXPRESS OR IMPLIED, INCLUDING, BUT NOT LIMITED TO, THE IMPLIED WARRANTIES OF NON-INFRINGEMENT, MERCHANTABILITY OR FITNESS FOR A PARTICULAR PURPOSE. Some jurisdictions do not allow disclaimer of express or implied warranties in certain transactions, therefore, this statement may not apply to you.

This information could include technical inaccuracies or typographical errors. Changes are periodically made to the information herein; these changes will be incorporated in new editions of the publication. Lenovo may make improvements and/or changes in the product(s) and/or the program(s) described in this publication at any time without notice.

The products described in this document are not intended for use in implantation or other life support applications where malfunction may result in injury or death to persons. The information contained in this document does not affect or change Lenovo product specifications or warranties. Nothing in this document shall operate as an express or implied license or indemnity under the intellectual property rights of Lenovo or third parties. All information contained in this document was obtained in specific environments and is presented as an illustration. The result obtained in other operating environments may vary.

Lenovo may use or distribute any of the information you supply in any way it believes appropriate without incurring any obligation to you.

Any references in this publication to non-Lenovo Web sites are provided for convenience only and do not in any manner serve as an endorsement of those

Web sites. The materials at those Web sites are not part of the materials for this Lenovo product, and use of those Web sites is at your own risk.

Any performance data contained herein was determined in a controlled environment. Therefore, the result obtained in other operating environments may vary significantly. Some measurements may have been made on development-level systems and there is no guarantee that these measurements will be the same on generally available systems. Furthermore, some measurements may have been estimated through extrapolation. Actual results may vary. Users of this document should verify the applicable data for their specific environment.

Trademarks

Lenovo, the Lenovo logo, ThinkCentre, and ThinkVantage are trademarks of Lenovo in the United States, other countries, or both.

Microsoft, Windows, and Windows Vista are trademarks of the Microsoft group of companies.

Other company, product, or service names may be trademarks or service marks of others.

Electronic emission notices

For electronic emission information on Class B digital devices, refer to the appendices in the user guide.



Korea Class B compliance statement

B급 기기(가정용 방송통신기자재)
이 기기는 가정용(B급) 전자파적합기기로서 주로 가정에서 사용하는 것을 목적으로 하며, 모든 지역에서 사용할 수 있습니다

Federal Communications Commission (FCC) and telephone company requirements

1. This device complies with Part 68 of the FCC rules. A label is affixed to the device that contains, among other things, the FCC registration number, USOC, and Ringer Equivalency Number (REN) for this equipment. If these numbers are requested, provide this information to your telephone company.

Note: If the device is an internal modem, a second FCC registration label is also provided. You may attach the label to the exterior of the computer in which you install the Lenovo modem, or you may attach the label to the external DAA, if you have one. Place the label in a location that is easily accessible, should you have need to provide the label information to the telephone company.

2. The REN is useful to determine the quantity of devices you may connect to your telephone line and still have those devices ring when your number is called. In most, but not all areas, the sum of the RENs of all devices should not exceed five (5). To be certain of the number of devices you may connect to your line, as determined by the REN, you should call your local telephone company to determine the maximum REN for your calling area.
3. If the device causes harm to the telephone network, the telephone company may discontinue your service temporarily. If possible, they will notify you in advance; if advance notice is not practical, you will be notified as soon as possible. You will be advised of your right to file a complaint with the FCC.
4. Your telephone company may make changes in its facilities, equipment, operations, or procedures that could affect the proper operation of your equipment. If they do, you will be given advance notice to give you an opportunity to maintain uninterrupted service.
5. If you experience trouble with this product, contact your authorized reseller or call the Customer Support Center. In the United States, call **1-800-426-7378**. In Canada, call **1-800-565-3344**. You may be required to present proof of purchase. The telephone company may ask you to disconnect the device from the network until the problem has been corrected, or until you are sure the device is not malfunctioning.
6. No customer repairs are possible to the device. If you experience trouble with the device, contact your Authorized Reseller or see the Diagnostics section of this manual for information.
7. This device may not be used on coin service provided by the telephone company. Connection to party lines is subject to state tariffs. Contact your state public utility commission or corporation commission for information.
8. When ordering network interface (NI) service from the local Exchange Carrier, specify service arrangement USOC RJ11C.

Canadian Department of Communications certification label

NOTICE: The Industry Canada label identifies certified equipment. This certification means that the equipment meets telecommunications network protective, operational and safety requirements as prescribed in the appropriate Terminal Equipment Technical Requirements documents. The Department does not guarantee the equipment will operate to the user's satisfaction.

Before installing this equipment, users should ensure that it is permissible to be connected to the facilities of the local telecommunications company. The equipment must also be installed using an acceptable method of connection. The customer should be aware that compliance with the above conditions may not

prevent degradation of service in some situations. Repairs to certified equipment should be coordinated by a representative designated by the supplier. Any repairs or alterations made by the user to this equipment, or equipment malfunctions, may give the telecommunications company cause to request the user to disconnect the equipment.

Users should ensure for their own protection that the electrical ground connections of the power utility, telephone lines, and internal metallic water pipe system, if present, are connected together. This precaution may be particularly important in rural areas.

CAUTION:

Users should not attempt to make such connections themselves, but should contact the appropriate electric inspection authority, or electrician, as appropriate.

NOTICE: The Ringer Equivalence Number (REN) assigned to each terminal device provides an indication of the maximum number of terminals allowed to be connected to a telephone interface. The termination on an interface may consist of any combination of devices subject only to the requirement that the sum of the Ringer Equivalence Numbers of all the devices does not exceed 5.

Polyvinyl Chloride (PVC) cable and cord notice

WARNING: Handling the cord on this product or cords associated with accessories sold with this product will expose you to lead, a chemical known to the State of California to cause cancer, and birth defects or other reproductive harm. ***Wash hands after handling.***

China substance disclosure table

产品中有毒有害物质或元素的名称及含量

部件名称	有毒有害物质或元素					
	铅(Pb)	汞(Hg)	镉(Cd)	六价铬 (Cr(VI))	多溴连苯 (PBB)	多溴二苯醚 (PBDE)
印刷电路板组件*	X	O	O	O	O	O
硬盘	X	O	O	O	O	O
光驱	X	O	O	O	O	O
内存	X	O	O	O	O	O
电脑I/O 附件	X	O	O	O	O	O
电源	X	O	O	O	O	O
键盘	X	O	O	O	O	O
鼠标	X	O	O	O	O	O
机箱/ 附件	X	O	O	O	O	O

○:表示该有毒有害物质在该部件所有均质材料中的含量均在SJ/T11363-2006标准规定的限量要求以下
 ×:表示该有毒有害物质至少在该部件的某一均质材料中的含量超出SJ/T11363-2006标准规定的限量要求
 表中标有“×”的所有部件都符合欧盟RoHS 法规。

印刷电路板组件*: 包括印刷电路板及其零部件、电容和连接器
 根据型号的不同, 可能不会含有以上的所有部件, 请以实际购买机型为准



在中华人民共和国境内销售的电子信息产品必须标识此标志, 标志内的数字代表在正常使用状态下的产品的环保使用期限

China recycling information for Waste Electrical and Electronic Equipment (WEEE)

《废弃电器电子产品回收处理管理条例》提示性说明

联想鼓励拥有联想品牌产品的用户当不再需要此类产品时, 遵守国家废弃电器电子产品回收处理相关法律法规, 将其交给当地具有国家认可的回收处理资质的厂商进行回收处理。更多回收服务信息, 请点击进入 <http://support.lenovo.com.cn/activity/551.htm>。

Turkish statement of compliance

The Lenovo product meets the requirements of the Republic of Turkey Directive on the Restriction of the Use of Certain Hazardous Substances in Electrical and Electronic Equipment (EEE).

Türkiye EEE Yönetmeliğine Uygunluk Beyanı

Bu Lenovo ürünü, T.C. Çevre ve Orman Bakanlığı'nın "Elektrik ve Elektronik Eşyalarda Bazı Zararlı Maddelerin Kullanımının Sınırlandırılmasına Dair Yönetmelik (EEE)" direktiflerine uygundur.

EEE Yönetmeliğine Uygundur.

Ukraine RoHS Statement

Цим підтверджуємо, що продукція Леново відповідає вимогам нормативних актів України, які обмежують вміст небезпечних речовин

ENERGY STAR model information



ENERGY STAR® is a joint program of the U.S. Environmental Protection Agency and the U.S. Department of Energy aimed at saving money and protecting the environment through energy efficient products and practices.

Lenovo is proud to offer our customers products with an ENERGY STAR compliant designation. Some models of the following machine types have been designed and tested to conform to the ENERGY STAR program requirement for computers at the time of manufacture: 0267, 0268, 0385, 1730, 5048, and 5049. For more information about ENERGY STAR ratings for Lenovo computers, go to <http://www.lenovo.com>.

By using ENERGY STAR compliant products and taking advantage of the power-management features of your computer, you reduce the consumption of electricity. Reduced electrical consumption contributes to potential financial savings, a cleaner environment, and the reduction of greenhouse gas emissions.

For more information about ENERGY STAR, go to:
<http://www.energystar.gov>

Lenovo encourages you to make efficient use of energy an integral part of your day-to-day operations. To help in this endeavor, set the following power-management features to take effect when your computer has been inactive for a specified duration:

Table 1. ENERGY STAR power-management features, by operating system

Windows Vista and Windows 7
Power plan: ThinkCentre Default <ul style="list-style-type: none">• Turn off the display: After 10 minutes• Put the computer to sleep: After 25 minutes• Advanced power settings:<ul style="list-style-type: none">– Turn off hard disk drives: After 20 minutes– Hibernate: Never

To awaken your computer from a Sleep or Standby mode, press any key on your keyboard. For more information about these settings, refer to your Windows Help and Support information system.

lenovo®

Part Number: 0B39663

Printed in USA

(1P) P/N: 0B39663

